



MC12 / MC18 / MC30

Accurate volumetric dosing of additives

The MC12, MC18 and MC30 are our showpieces in volumetric dosing. These dosing units have proved their value since Movacolor started. The units are installed in factories all over the world and can operate under almost any conditions.

Depending on the material, the unit can be tailor-made for dosing free-flowing powders, regrinds or normal granulates. The units add additive on the basis of volume. The MC12 and MC18 units are controlled by rpm setting. The MC30 can be pre-calibrated to dose at percentage rates.

The Movacolor dosing cylinder® in combination with the stepper motor ensures maximum control with no stoppages or pulsations. The MC18 and MC30 can be equipped with an automatic hopper loader for automatically filling the stainless steel hopper.

Features

- Accurate dosing through dosing cylinder
- Stepper motor speed starting from 0.1 up to 200 rpm
- Manual adjustment

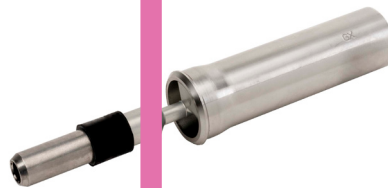

MC12 Economy

The MC12 features manual adjustment of metering speed and time. The unit also works in relay mode for extrusion applications. It has a 4-piece 7 segments LED display, keypad operated and keypad lock function.



MC18 Synchronic

The MC18 has all the features of the MC12 plus automatic synchronization to extruder speed and integrated hopper loader control and an alarm output.



MC30 Auto-Calibrate

The MC30 has an automatic material calibration function and a recipes storage function. The menu-guided control has a graphic LCD display with backlight. A warning and alarm output and an integrated hopper loader control are also part of the MC30. This volumetric dosing unit is suitable for both injection molding and extrusion.



MOVACOLOR LEADING INNOVATOR IN DOSING TECHNOLOGY

For almost three decades, Movacolor has been dedicated to coloring the world in a sustainable way. We do so by developing high-precision gravimetric and volumetric dosing systems. Our knowledge, experience and innovation capabilities are invested in a comprehensive portfolio of user-friendly products. These work easily and effortlessly together in advanced systems that conserve additives, increase production flexibility and deliver excellent results.

MC12/MC18/MC30

Technical specifications

CAPACITY

- MC12: 0.07-72 kg/h
- MC18 and MC30: 0.07-180 kg/h

APPLICATIONS

Injection molding and extrusion

POWER SUPPLY

80-260 VAC, 50/60 Hz. By integrated automatic voltage selector

POWER CONSUMPTION

80 Watt maximum

LANGUAGES

MC30: English, German*

OPERATION

- MC12 and MC18: keypad
- MC30: menu guided control, LCD display

INPUT SIGNALS

Start input: potential free, 24 VDC or extruder tachometer (0-30 VDC) (tachometer only for MC18 and MC30)

OUTPUT SIGNALS

- MC18: alarm, valve (for hopper loader control)
- MC30: alarm, warning, run, valve (for hopper loader control)

* additional languages on request



Dimensions volumetric unit

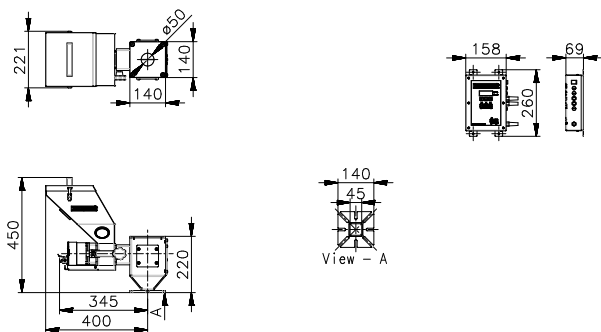

Dimensions MC12 and MC18

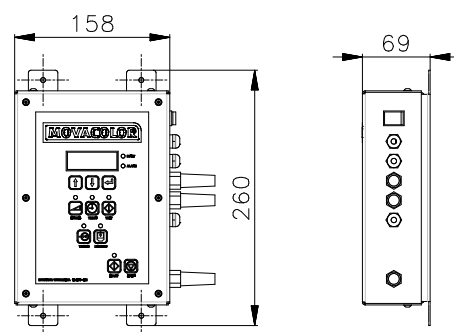

Dimensions MC30

